

# AKIRA

makes life better

---

## Air Conditioner Service Manual



Большая библиотека технической документации

<https://splitsystema48.ru/instrukcii-po-ekspluatacii-kondicionerov.html>

каталоги, инструкции, сервисные мануалы, схемы.

**MODEL:  
AC-S19CLG1**

---

## CONTENTS

TECHNICAL SPECIFICATION.....	4
PARTS NAME.....	5
SYSTEM DAIGRAM.....	6
CIRCUIT DIAGRAM.....	8
DISASSEMBLY PROCEDURES.....	9
EXPLODED VIEW AND PARTS LIST.....	18
GUIDE FOR INSTALLATION.....	22
CARE AND MAINTENANCE.....	29
MULFUNCTION ANALYSIS.....	30

**TECHNICAL SPECIFICATION**

Model		<b>AC-S19CLG1</b>	
Function		Cooling	/
Power Supply		1Ph 230V / 50Hz	
Capacity (Btu/h)		15500	/
Rated Input (W)		2350	/
Rated Current (A)		10.2	/
Air Flow (m <sup>3</sup> /h)		620	
Dehumidifying Volume (L/h)		1.8	/
EER (W / W)		2.5	/
Indoor Unit	Model		<b>AC-S18CLG1</b>
	Motor Fan Speed (rpm)		1350
	Output Fan Power (W)		22
	Fan Type / Piece		Cross Flow Fan – 1
	Diameter – Length		Φ 92mm – 616mm
	Evaporator		Aluminum Fin – Copper Tube
	Row-Fin Distance (mm)		2 – 1.4
	Swing Motor		MP 28 EA
	Fuse (A)		PCB 3.15A Transformer 0.2A
	Noise (db / (A))		< 37
	Dimension (w x h x d)(mm)		830 x 220 x 285
	Net Weight (kg)		11
Outdoor Unit	Model		<b>AC-S18CLG1</b>
	Input Power (W)		1850 /
	LRA (A)		46.5
	Throttling Method		Capillary
	Compressor		ROTARY
	Working Temp.		< 43° C
	Condenser		Aluminum Fin-Copper Tube
	Pipe-Diameter (mm)		9.52
	Row-Fin Distance (mm)		2 – 1.4
	Working Area		/
	Fan Motor Power (W) Speed (rpm)		48 / 885
	Fan Type-Piece		Axial Flow Fan – 1
	Diameter (mm)		409
	Defrosting Method		Auto Defrosting
	Noise (db/ (A))		< 57
	Dimension (w x h x d) (mm)		848 x 540 x 320
	Net Weight (kg)		40
	Refrigerant Charge		R22 / 1.25
Connecting Pipe	Outer Diameter	Liquid (mm)	Φ 6
		Gas pipe (mm)	Φ 12
	Max. Distance	Height (m)	5
		Length (m)	10

The technical data are subject to change without notice. Please refer to the nameplate of the unit.

**PARTS NAME**

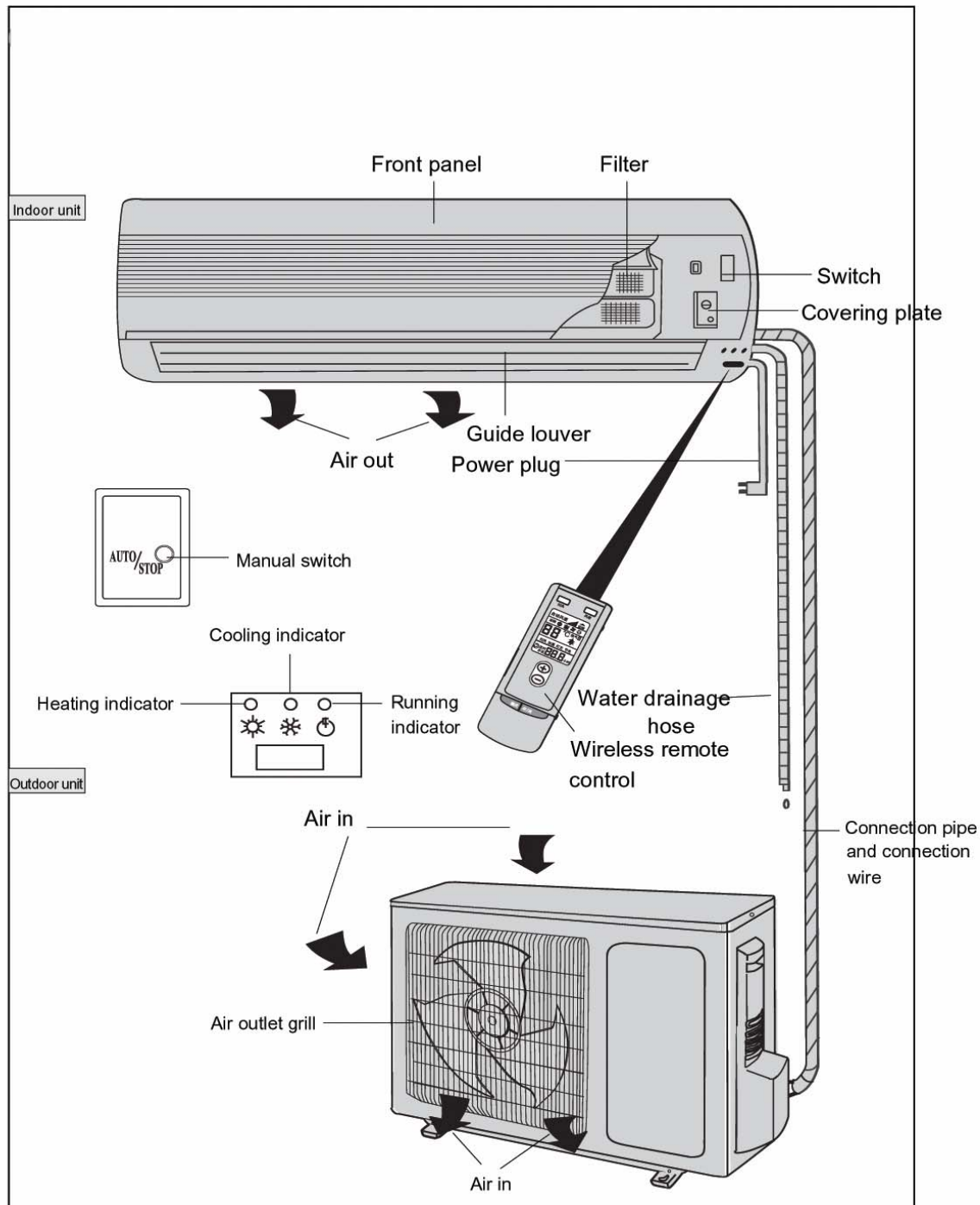

**SYSTEM DIAGRAM**

**System diagram for cooling only type**

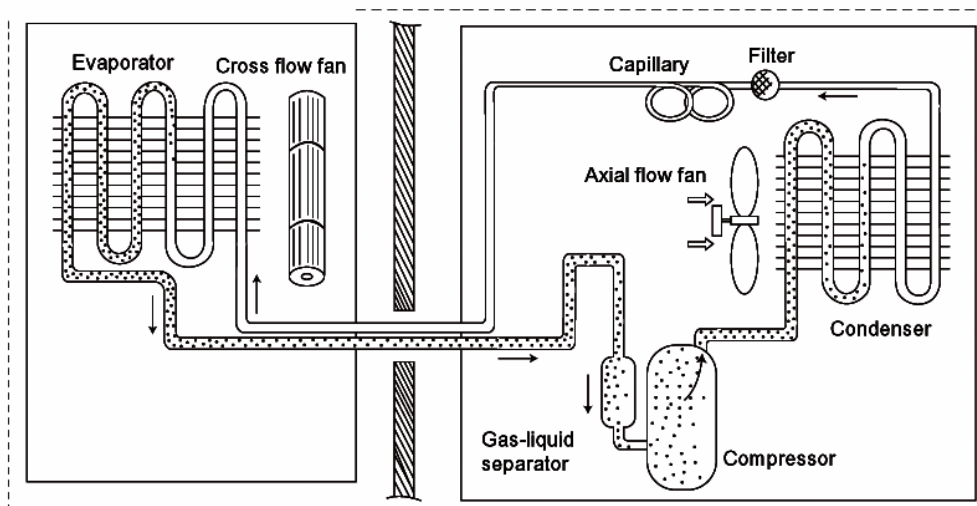

When the power is on, the unit start to work. The compressor sucks low-pressure refrigerant gas from the evaporator and discharges high-temperature and high-pressure gas into condenser. Then air exchanges the heat with outdoor air and becomes refrigerant liquid. The liquid is throttled by the capillary and changes into low-pressure liquid and low-pressure liquid and then flows into indoor evaporator. The liquid exchanges the heat and changes into low-temperature and low-pressure refrigerant gas, the cycle introduced above goes on and on, and the demanded low temperature environment is maintained.

### System diagram for cooling and heating type

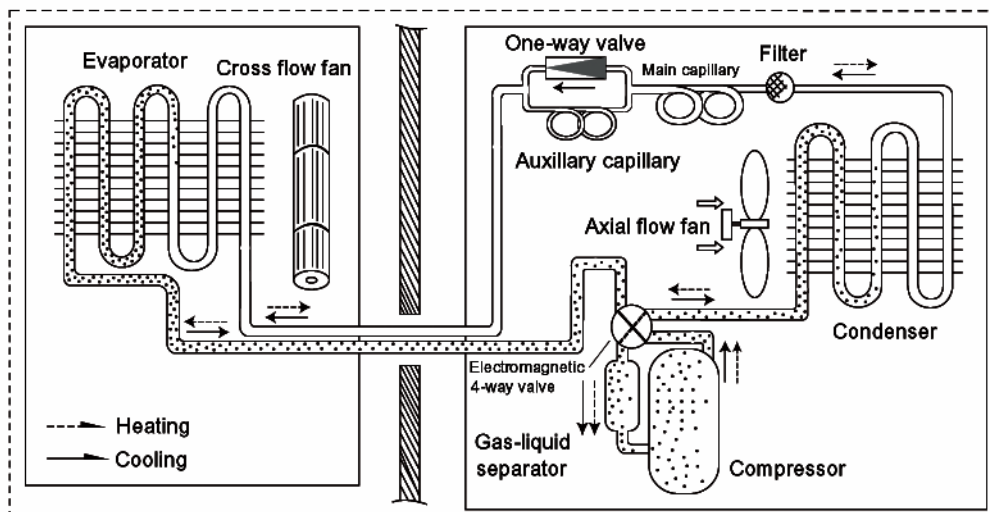

When the power is on, indoor and outdoor units will start to run. When the system operates in cool mode, the compressor sucks low-temperature refrigerant gas from the evaporator and sucked by compressor, compressor into high-temperature, high-pressure Gas, and then discharges into condenser, heat exchanges with the outdoor air becomes into refrigerant liquid, the liquid is throttled by the capillary and the temperature and pressure lower down, enter into the evaporator, heat exchanges with the indoor air which need to be adjusted, then changes into low-temperature, low-pressure refrigerant gas, the cycle introduced above goes on and on, the demanded low temperature environment is maintained. (when in heat mode, the 4way valve changes its way and the refrigerant flows in the reversible cycle, to make the condenser sucks heat, evaporator discharges heat, and the demanded high temperature environment is maintained.

## CIRCUIT DIAGRAM

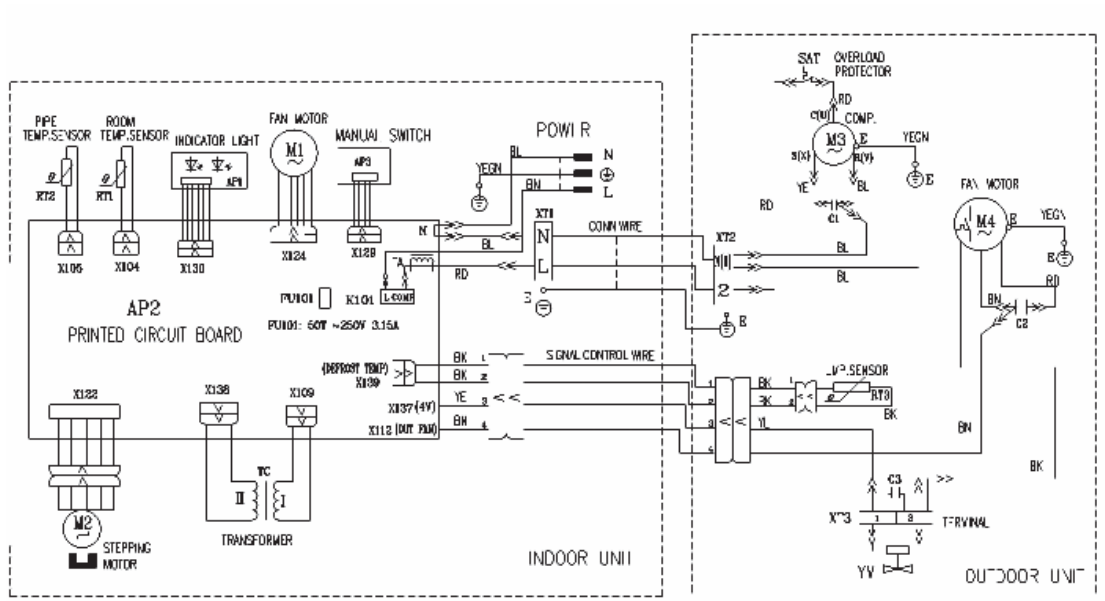



## DISASSEMBLY PROCEDURES

### Operation procedures/pictures

#### Disassemble the front panel

Raise up the front panel, take out the front panel.

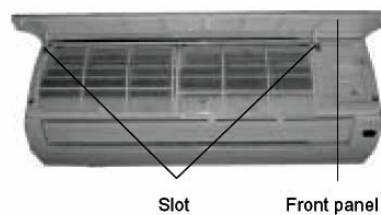

#### Remove filter and wire-pressed clamp

To remove the filter, and screw off 1pc bolt which fixed the wire-pressed clamp to disassemble the wire-pressed clamp.

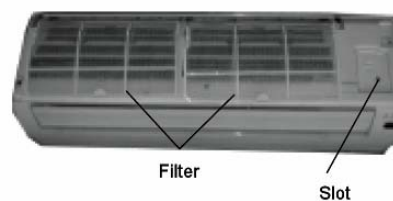

#### Disassemble the guide louver

Disassemble the big guide louver and small guide louver.

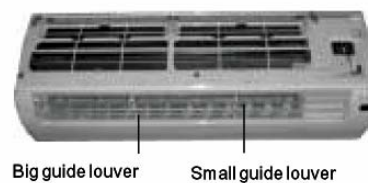

## Operation procedures/pictures

### **3.1.4** Disassemble the front case

To loose the clasp

To remove the screw cap, to loose 3pcs screw, raise it up, disassemble the front case.

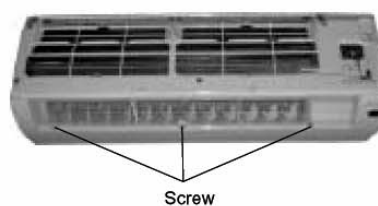
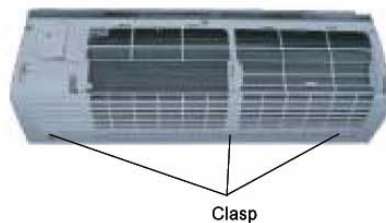

### **3.1.5** Remove the electric box cover

To loose the clasp which fix the electric box, to remove the electric box cover.

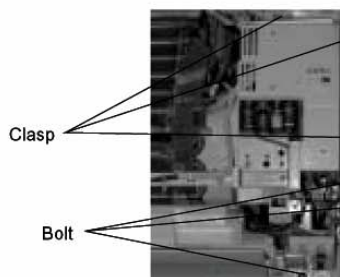

### **3.1.6** Remove the water tray sub-assy

To pull out the terminal of the stepping motor, screw off the bolt to remove the water tray sub-assy. Because of the water drainage pipe, please be careful.

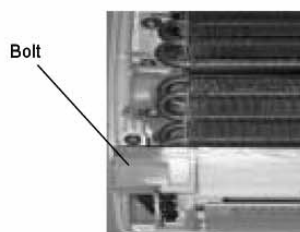

## Operation procedures/pictures

### Disassemble the electric box

Untie the bunch of wire, to loosen the screws on electric box indicator seat, to loosen the earth screw, take out the sensor.

Pull out each terminal, take out the control board.

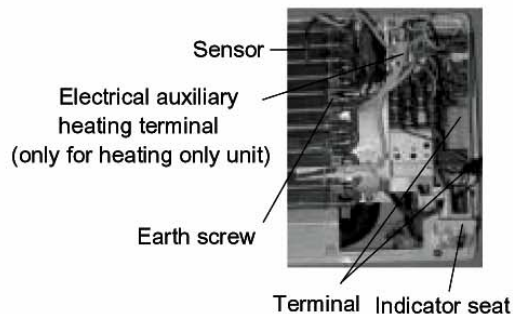

### Disassemble the evaporator

Remove the pipe clamp behind of the rear case. To screw off the bolt of the rear clamp. Then press the clasp forcibly, to pull out the rear clamp.

to screw off two pcs on the left and right side of the evaporator. To press the left nether end of the evaporator, then press it backward, to remove the evaporator side plate clasp from the slot.

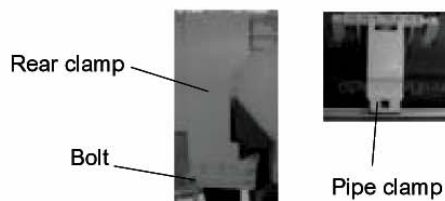

Be carefully to take out the evaporator, please take care of the connection pipe.

## Operation procedures/pictures

### Remove the motor

Loosen the bolt which fixed the motor clamp, take out the motor clamp.

To loose a fixed bolt which is on the right bearing of cross flow fan, lift up the motor appreciably, then take out the motor.



Bolt

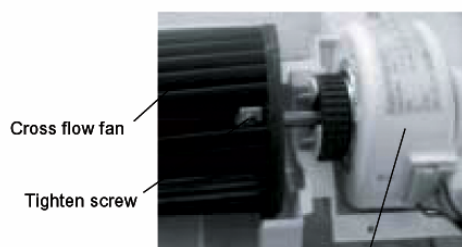

Motor

### Remove the cross flow fan

Loosen one piece of bolt which fixed the cross flow fan, then can take out the cross flow fan.

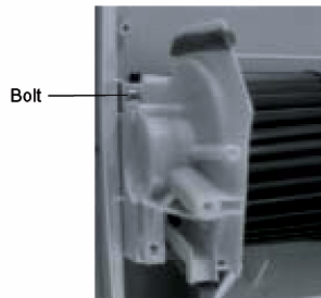

Bolt

## Operation procedures/pictures

### Disassemble the big handle

To screw off the tapping screw which fixed the big handle, could take out the big handle.

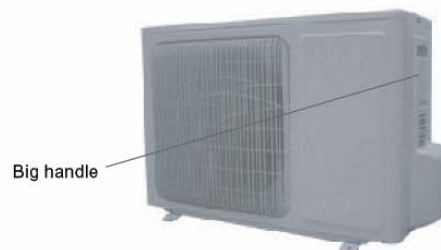

### Disassemble the top cover plate

To screw off 3pcs tapping screw which around the top cover, then lift it up, can take down the top cover.

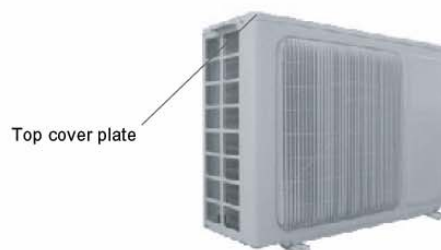

### Disassemble the rear grill

To screw off 4pcs tapping screw of the rear grill, can take off the rear grill.



## Operation procedures/pictures

### Disassemble the front panel sub-assy

To screw off 5pcs tapping screws which come from the front panel, valve support, chassis and side plate of the condenser, then can take out the front panel sub-assy.

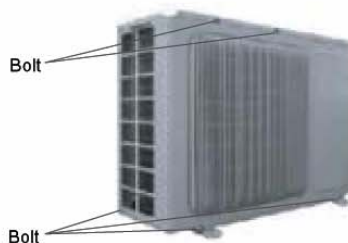

### Remove the electric appliance mounting board

To screw off 1pc bolt which fixed the electric appliance mounting board, take out the leading wire insert from the compressor and fan motor, take out the electric appliance mounting board.

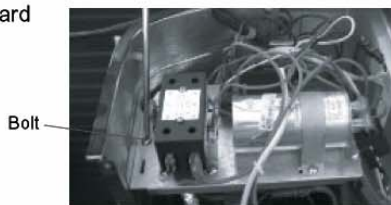

### Disassemble the right side plate

To screw off 7pcs bolt of the rear side plate, then can disassemble the right side plate.

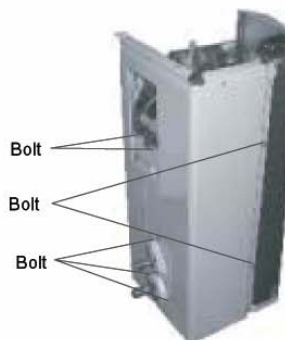

## Operation procedures/pictures

### Remove the axial flow fan

To loosen tighten nut with spanner (levorotation), take off the nut, spring washer, flat washer, and take out the axial flow fan forcibly.

Tighten nut  
Axial flow fan

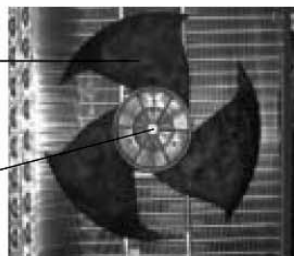

### Remove the motor, motor support

To screw off 4pcs tapping screw which fixed the motor, take out the motor. And screw off 2pcs tapping screw which fixed the motor support, lift it up, take out the motor support.

Motor support  
Tapping screw  
Motor

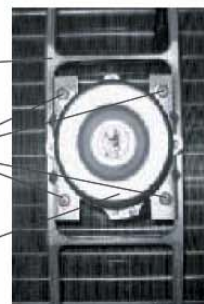

### Remove the 4-way valve (Only for heating only unit)

To screw off the tighten nut from the 4-way valve loops, then take out the loop, enwrap the 4-way vavie with wet cloth, unsolder 4pcs soldered point which connected with the 4-way valve, take out the 4-way valve.

The solder procedure should be as quick as possible, make sure that the guaze should keep wet, do not let the flame to damage the compressor lead wire.



Tighten screw  
Solenoid coil

Soldered

Disassemble capillary

Unsolder the soldered point between capillary, valve and outlet pipe of condenser, can disassemble the capillary, when changing the capillary, do not let dregs block the capillary.



Disassemble the gas valve and liquid valve

To screw off 2pcs bolt which fixed the gas valve, then unsolder the soldered point between the gas valve and air return connection pipe, take off the gas valve.

(NOTE: When unsolder the soldered point, it is need to enwrap the gas valve with wet cloth, avoiding valve be damaged by high temp.)

To screw off 2pcs bolt which fixed the liquid valve, then unsolder the soldered point between the liquid valve and forked pipe, take off the liquid valve.

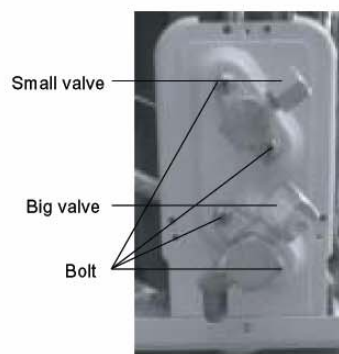



Disassemble the compressor

Loosen 3pcs nut with washer at the compressor button;

(NOTE: It's need to discharge the refrigerant first.)

Unsolder the soldered points of air in pipe and air out pipe,  
remove the pipeline carefully, take out the compressor.

Cooling only unit

Cooling and heating unit

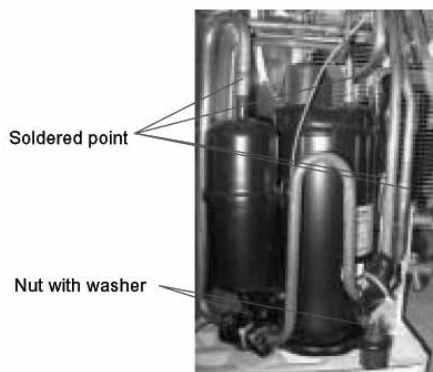
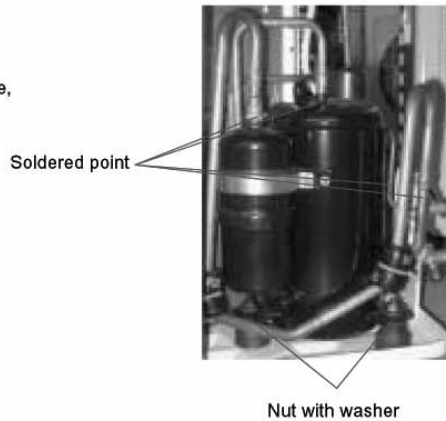

## EXPLODED VIEW – Indoor Unit

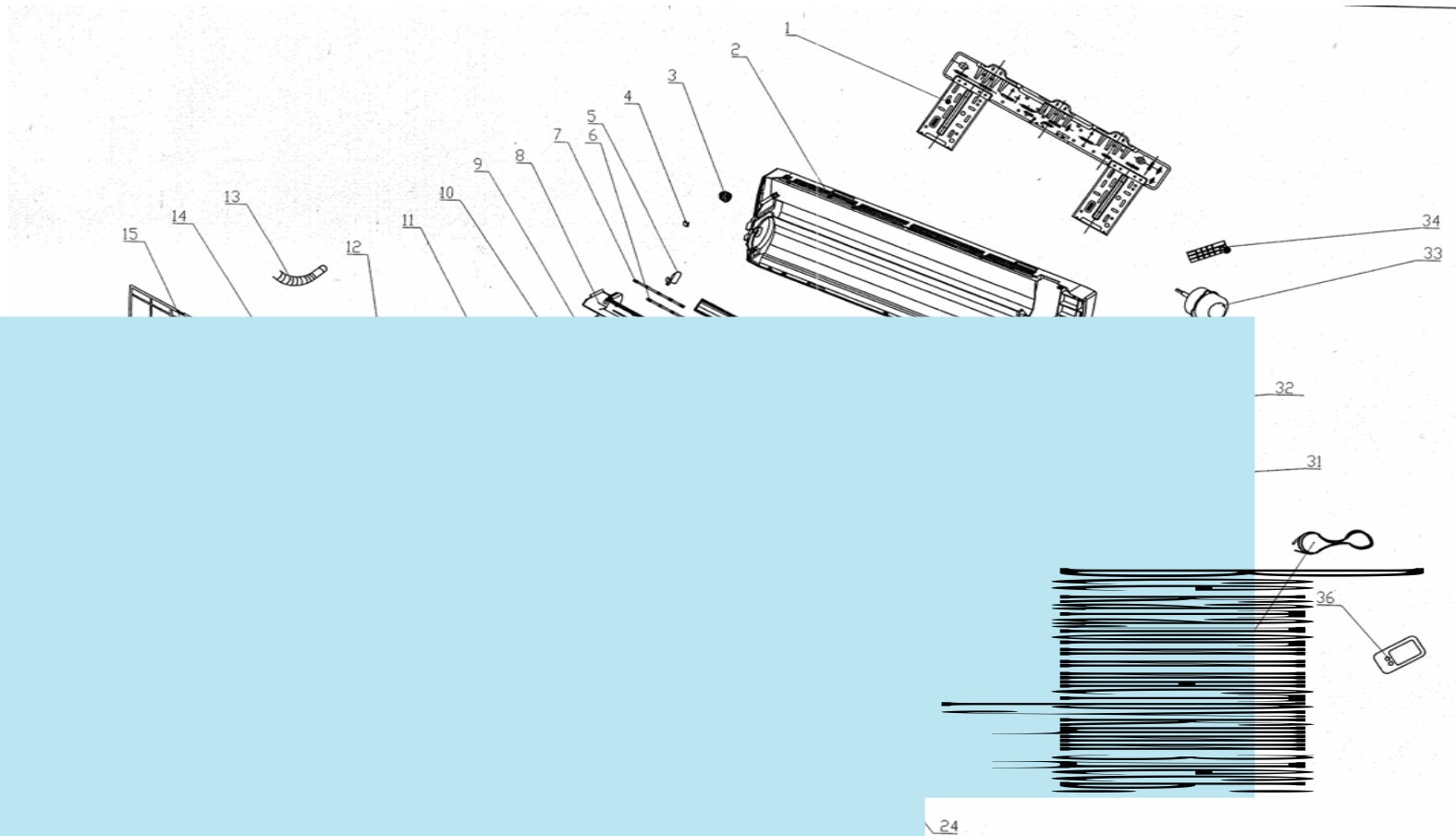

## PART LIST – Indoor Unit

NO.	Part Code	Part Description	Qty
1	01252384	Wall Mounting Frame	1
2	26112425	Pipe Clamp	1
3	262724216	Hook	2
4	22202051	Rear Case Sub-Assy	1
5	010021343	Evaporator Assy	1
6	10352005	Cross Flow Fan	1
7	76712015	Ring of Bearing	1
8		Fan Bearing	
9	261124281	Motor Left Clamp	1
10	05232411	Drain Pipe	1
11	00100000	...	1
		...	12
		...	1
		...	1
		...	1
		...	2
		...	1
		...	1
		...	1
		...	1
		...	1

## EXPLODED VIEW – Outdoor Unit

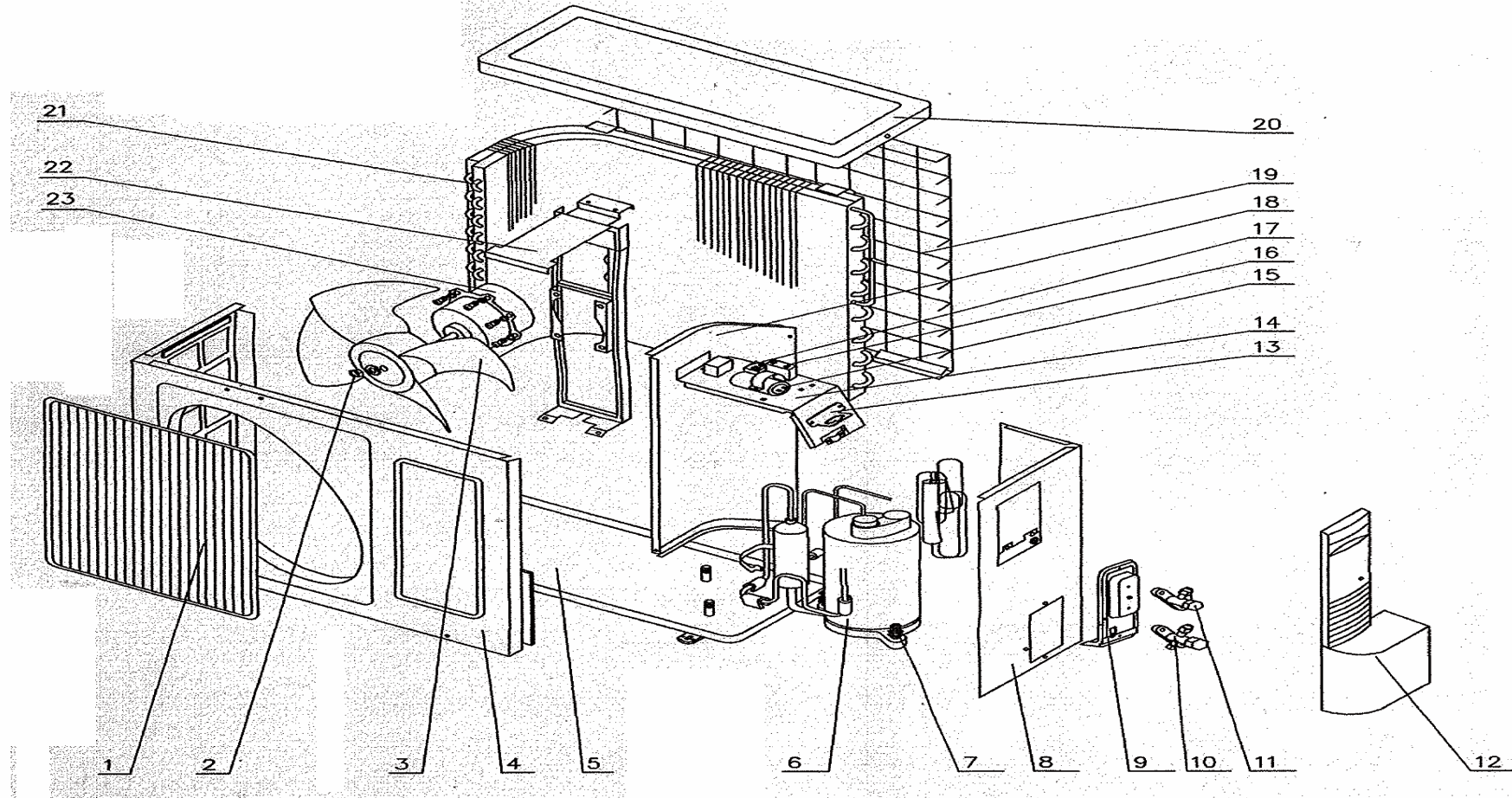

## PART LIST – Outdoor Unit

NO.	Part Code	Part Description	Qty
1	22413431	Grille	1
2	70310132	Nut M6	1
3	10335001	Axial-flow Fan	1
4	01533012	Panel	1
5	01205036	Underpan Sub-Assy	1
6	001001951	Compressor and Fittings	1
		Nut M8 w. washer	
7	70310012	compressor	3
8	01302004	Right Side Plate Sub-Assy	1
9	01713041	Valve Support	1
10	07100147	Valve 1/2	1
11	07100120	Valve 1/4	1
12	26233433	Big Handle	1
13	42011113	Terminal Board	1
14	01403117	Electric Box Sub-Assy	1
15	33000001	Capacitor	1
16	33010027	Capacitor	1
17		Terminal Board 2-8	
18	01235001	Clapboard Sub-Assy	1
19	01473030	Rear Grill	1
20	01253443	Top Cover Board	1
21	011035772	Condenser Assy	1
22	01703381	Motor Support Sub-Assy	1
23	15013047	Fan Motor	1

**The data are subject to change without prior notice**

## GUIDE FOR INSTALLATION

### Guide for installation

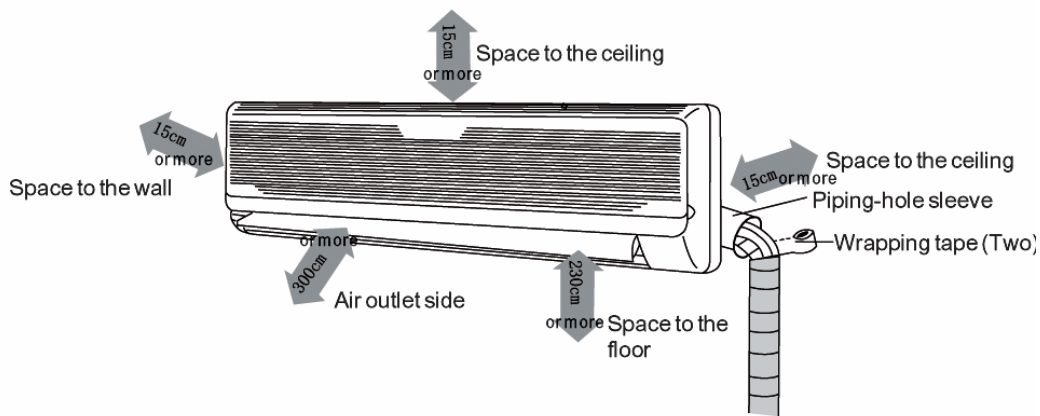

### Important Notes

- ★ The installation must be done by trained and qualified service personnel with reliability according to this manual.
- ★ Contact service center of GREE before installation to avoid the malfunction due to unprofessional installation.
- ★ When picking up and moving the units, you must be guided by trained and qualified personnel.
- ★ The distance between the air outlet vent and heat source, or inflammables should be more than 50cm.

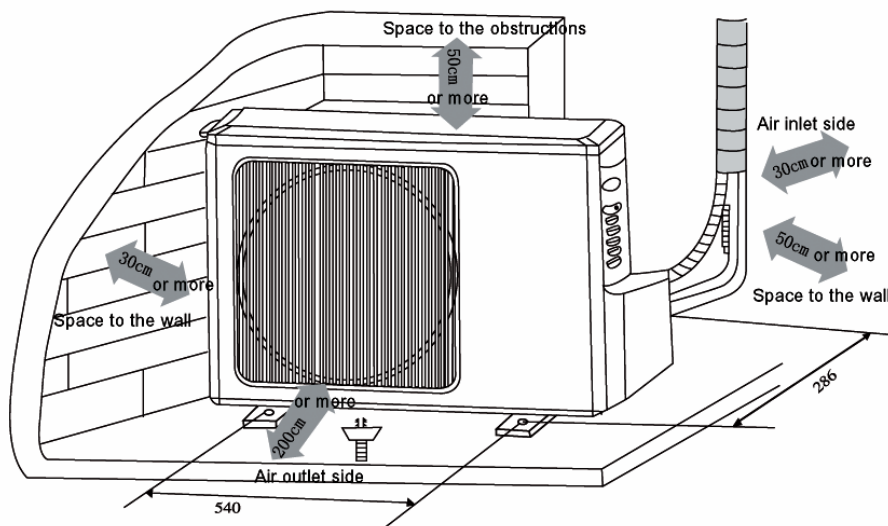

## Selection of installation location

### 1 Indoor unit

- The inlet and outlet should be far away from the obstructions so that the outflow air can reach all parts of the room;
- Install in a location connect with the outdoor unit easily;
- Install in a location from which the condensation water can be drained out conveniently;
- Avoid a location where there is heat source, steam or inflammable gas;
- Install in a location where is strong enough to withstand the full weight and vibration of the unit;
- Be sure that the installation conforms to the installation dimension diagram;
- Be sure to leave enough space to allow access for routine maintenance, the height between the indoor unit and outdoor unit should be more than 200cm;
- Select a place about 1 meter away from the TV set or any other electric appliances;
- The place where the air filter can be easily taken out.
- Avoid to use the unit in the places near the laundry, bathroom, or swimming pool.

### 2 Outdoor unit

- Select a place from which noise and outflow air emitted by unit will not inconvenience neighbors.
- Select a location where there should be sufficient ventilation.
- There are should be no obstructions block the air inlet and air outlet vents near the outdoor unit.
- The location should be able to withstand the full weight and vibration of the outdoor unit and permit safe installation.
- There should be no danger of flammable gas or corrosive gas leaks.
- Be sure that the installation conforms to the installation dimension diagram.

### NOTE:

Install in the following place may cause malfunction. If it is unavoidable, contact the dealer please.

- The place where oil (machine oil) is used.
- The place where a lot of salinities such as coast exists.
- The place where a sulfured gas such as the hot spring zones is generated.
- The palce where high-frequency waves are generated by radio equipment, welders and medical equipment.
- Other place with special circumstance.



## Install the indoor unit

### 1 Install the wall mounting plate

- Measure horizon by handling line or horizontal measurement. Since drainage pipe hole is on left side, when adjusting panel, the left should never be higher; it is better to make it lower.
- Fix the wall mounting plate on the selected location with screws.
- Pull the rear panel by hands after installation to see if it is firm enough. The rear panel should be able to stand the weight of an adult (60kg) and the weight should be evenly shared by each screw.

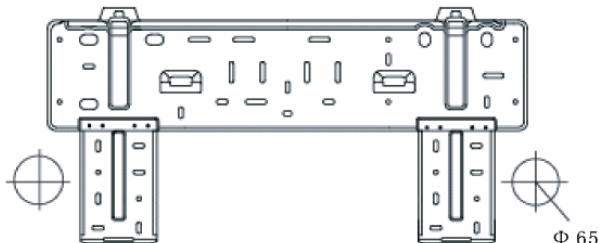
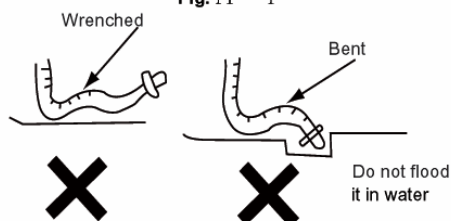

Fig. 11 - 1

### 2 Install drainage hose

- Drainage hose must be placed at a downward slant for smooth drainage.
- Do not wrench, bend or heave the hose or flood its end by water.



### 3 Open piping hole

- Drill a hole outward at a slant after accertaining location piping hole as in fig.11-1.  $\Phi$  65
- In order to prevent pipe and cable from damaging when going through the hole, install wall sleeve.

### 4 Install connection pipe

- Connect the connection pipe with two leading pipes from indoor unit, and then tighten the joint nuts on connection pipe.

NOTE:

- Connect connection pipes with indoor unit first and then outdoor unit.
- Bend the connection pipe carefully or it would be damaged.
- Don't tighten the joint nut too much or leakage would occur.

### 5 Electric wiring

- Open front panel upwardly.
- Take off covering plate.
- To pull out the power conneting cable from the back of the indoor unit, and put it through the wire hole, then connect with the power cable.
- As shown in Fig.11-2, connect the blue wire of power connect wire onto terminal "N", red wire onto terminal "2", brown onto terminal "3" and yellow-green one (earth wire) to terminal "⊕"
- Recover the wire covering plate.
- Cover the front panel.
- For heat pump type unit, to fix the signal control cable on the chassis by using wire clamp.



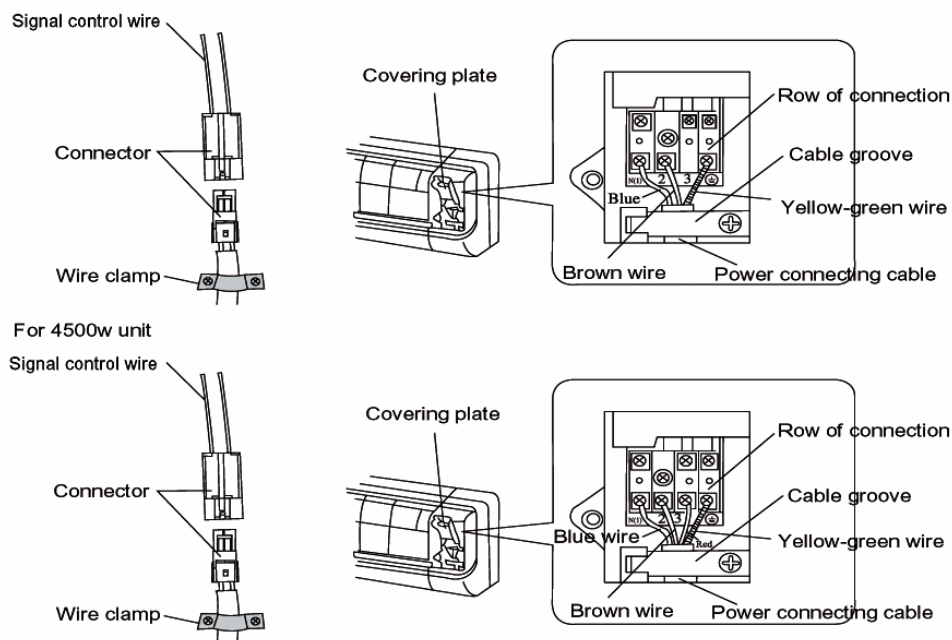

Fig.11-2

**NOTE:**

- All electric installation must be done by professional personnel according to local law, regulation and this manual.
- Power cable adopts Y type, if the power cable damaged, in order to avoid the danger, make sure to ask the manufacturer, after sales dealer or professional to replace.
- The power supply must adopt rated voltage and exclusive circuit for air conditioner.
- The creepage switch and air switch with suitable capacity must be installed, the 10A air switch is fit for the cooling capacity lower than 2500W unit (including 2500W), if the unit with cooling capacity higher than 2500W, the 16A air switch should be used.

**● Install indoor unit**

- When routing the pipe (wiring) from the left or right side, cut off the tailings of the left pipe on base of main unit. (as shown in Fig.11-3)

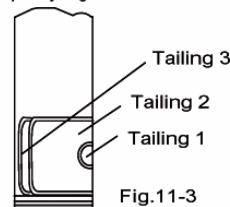

Fig.11-3

- ① Cut off tailing 1, tailing 2 only power cable is routed;
  - ② Cut off tailing 1, tailing 2 when connection pipe and power cord are routed;
- After wrapped piping and wiring, pull them through the piping hole; As shown in Fig.11-4
  - Put two claws which behind the indoor unit, to hang on the clamp of the wall mounting plate, and to move the unit left and right, to see it is firm or not.
  - Ensure that the install height of indoor unit is 2.3m or more.

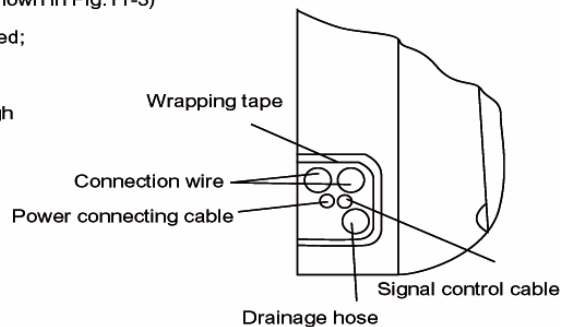

Fig.11-4

## Install outdoor unit

### 1) Install connection pipe

- Align the flare of connection pipe to the joint flare of corresponding valve.
- Tighten nuts on connection pipe forcibly then tighten it by spanner as shown in right figure.

NOTE: Too great of torque would damage nuts.

Refer the following list for tighten torque

Diameter of nut (mm)	Torque wrench (N·m)
Φ6	15~20
Φ9.5	31~35
Φ12	50~55

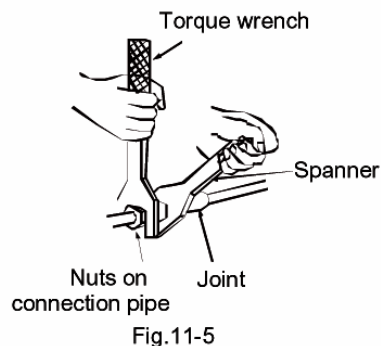

Fig.11-5

### 2) Wiring connection

- Disassemble the handle on the right side plate of the outdoor unit. (one screw)
- Disassemble the wire clamp, connect the power connecting cable onto the terminal and fix well. The wiring layout should be accord with indoor unit, to cut off the tailing of wire hole on the right side plate, then to put on the loop.
- To fix the power connecting cable with wire clamp, for cooling and heating unit, need to fix the signal control cable with wire clamp, then connect the corresponding connector.
- Make sure that the wiring are fixed well or not.
- Install the handle. ( fixed by one screw)

The synop for terminal connection

Terminal	Wire
N(1)	Blue
2	Brown
3	Red
⊕	Yellow-green

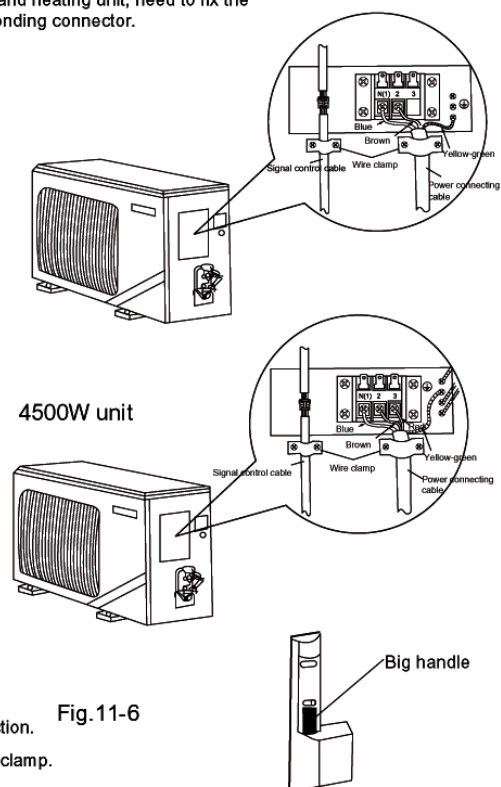

Fig.11-6

#### NOTE:

- Wrong wiring connection may cause electric appliance malfunction.
- Don't pull the electrical wire which had been fixed well by wire clamp.

### 3) Air purging and leakage test

- Remove the fluorine charging nozzle nuts cap on the gas valve.
- Align the center charging flexible tube which is on the vacuum gauge with the low(Lo)pressure port, then connect to the fluorine charging nozzle. (As shown in Fig.11-8)
- Start up the vacuum pump, when the hand pointed 1 bar, to close the low pressure (Lo) handle tightly, and stop the vacuumizing. And keep more than 15 minutes, make sure that the pressure of vacuum gauge is unchanged.
- Remove the valve caps of the gas valve and liquid valve.
- Slightly to loose the liquid valve stem with hex wrench, until the pressure of vacuum pump rise up to 0 bar above.
- Unhitch the charging pipe away from the fluorine charging nozzle, and tighten the nut cap of the charging nozzle.
- Open the valve stem of liquid valve and gas valve, with hex wrench.
- Tighten the valve caps of gas valve and liquid valve, and check the air leakage.

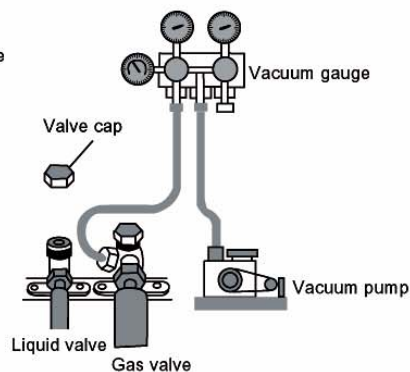

Fig.11 - 7

### 4) Outdoor condensation drainage (Heat pump type only)

- When the unit is heating, the condensing water and defrosting water formed in the outdoor unit can be drained out reliably through the drain hose.

#### Installation method:

Install the outdoor drain elbow in the hole on  $\phi 25$  hole on the base plate as shown in right figure, and joint the drain hose to the elbow, so that the waste water formed in the outdoor unit can be drained out to a proper place.

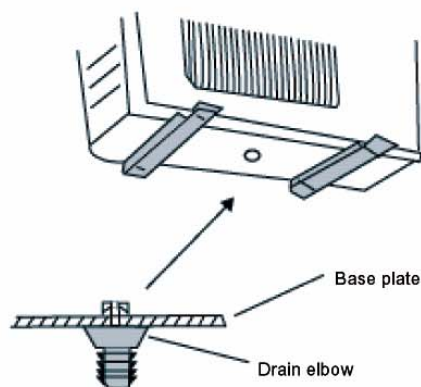

Fig.11-8

## Test operation and check after installation

### 1 Test operation

#### 1. Before test operation

- Do not switch on power before installation is finished completely.
- Electric wiring must be connected correctly and securely.
- Cut-off valves should be opened.
- All the impurities such as scraps and thums must be cleared from the unit.
- Open the front panel, set "Run" mode by the manual switch.

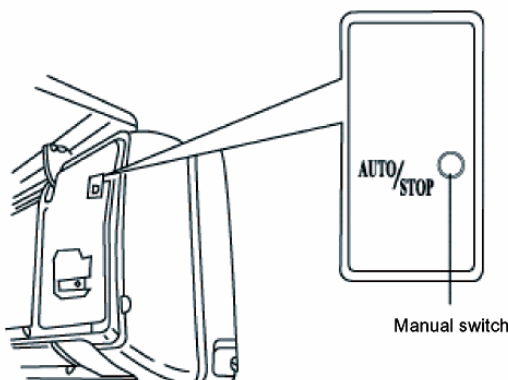

Fig. 11 - 9

#### 2. Test operation method

- Switch on power and press "1/0" button on the wireless remoter control.
- Press "MODE" button, select , , , to observe whether the running is normal or not.
- Emergency operation

If the wireless remote control is lost, emergency running can be operated as follow:

- ( 1 ) To set "AUTO" mode by manual switch, unit will automatically to select mode according to the room temp.by microcomputer.
- ( 2 ) In the running mode, to set the manual switch to "STOP", unit will stop running.

### 2 Check after installation

Items to be checked	Possible malfunction	Remarks
Has it been fixed firmly?	The unit may drop, shake or emit noise.	
Have you done the refrigerant leakage test?	It may cause insufficient refrigeration capacity.	
Is heat insulation sufficient?	It may cause condensation and dripping.	
Does the unit drain well?	It may cause condensation and dripping.	
Is the voltage in accordance with the rated voltage marked on the nameplate?	It may cause electric malfunction or damage the part.	
Is the electrical wiring and piping connection installed correctly and securely?	It may cause electric malfunction or damage the part.	
Has the unit been connected to a secure earth connection?	It may cause electrical leakage	
Is the power cord specified?	It may cause electric malfunction or damage the part.	
Has the inlet and outlet been covered?	It may cause insufficient refrigerating capacity.	
Has the length of connection pipes and the refrigerant charge been recorded?	The refrigerant capacity is not accurate.	

## CARE & MAINTENANCE

### Warning

- Turn power off and pull out the power plug before cleaning air conditioner. Or it may cause the electric shock.
- Never dampen the air conditioner, it can cause the electric shock. And never sprinkle water on the unit.
- Volatile liquid (e.g. thinner or gasoline) will damage the air conditioner. (So wipe the units with a dry soft cloth, or a cloth slightly moistened with water or cleanser.)



### Clean the surface panel

#### 1 Take down the front panel

Along the direction of arrows to pull of the front pannel an angle from the slots of the front pannel,then pull down the air filter and take it out.

#### 2 Clean the front panel

Use a soft brush with little water and detergent to clean, then to dry it in the shade.

#### 3 To install the front panel

To insert the supports of both sides into the supports' slot, and put the middle axis into the groove, then along the arrow direction to recover the front panel cover and clasp it.

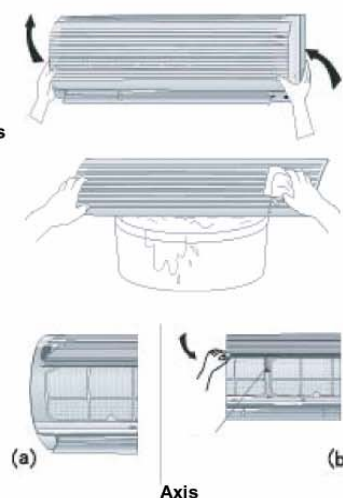

### Clean the filter

#### 1 Take down the filter

Along the direction of arrows to pull of the front pannel an angle from the slots of the front pannel,then pull down the air filter and take it out, as shown in the right Fig.

#### 2 Cleaning

To clear the dust adhering to the filters, you can either use a dust collector, or wash them with warm water(the water with the neutral detergent should below 45°C) when the filters are very dirty(such as oil stain),and dry it in the shadow. As shown in the right Fig.

#### 3 Reinsert the filter

Reinsert the filters with side marked , pay attention to the front side, then to clasp the front panel cover.

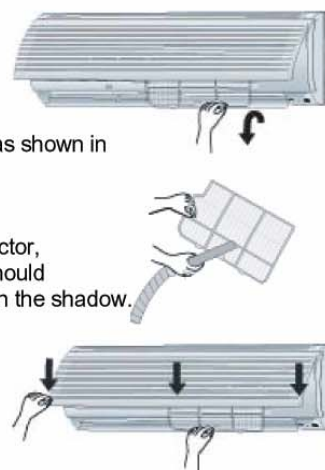

#### NOTE:

- Never to put the front panel or filter directly under the sun.
- Never use water above 45°C to wash the filters, or it could cause deformation or discoloration.
- Never parch it by fire, or it could cause a fire or deformation.

## MULFUNCTION ANALYSIS

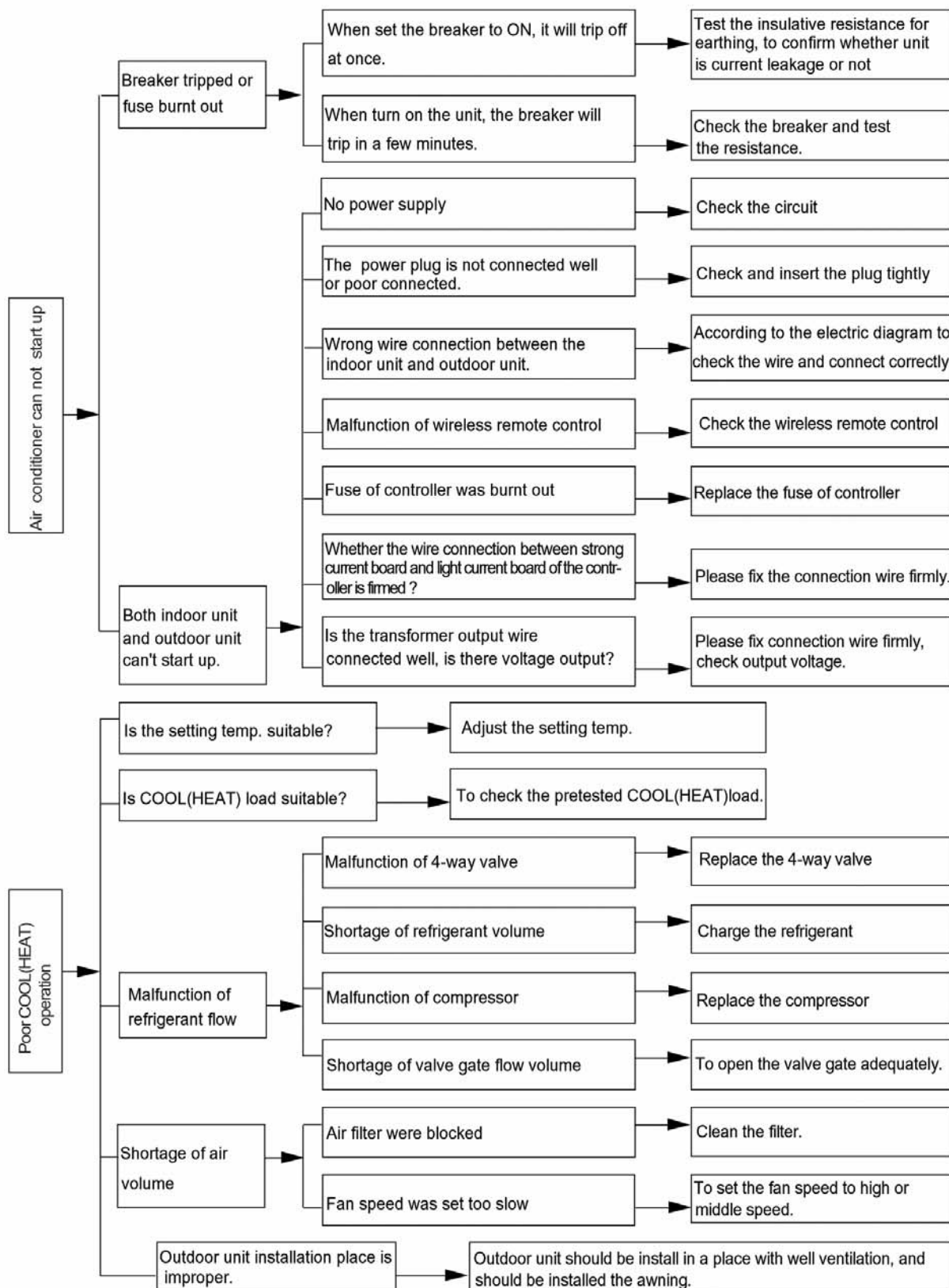

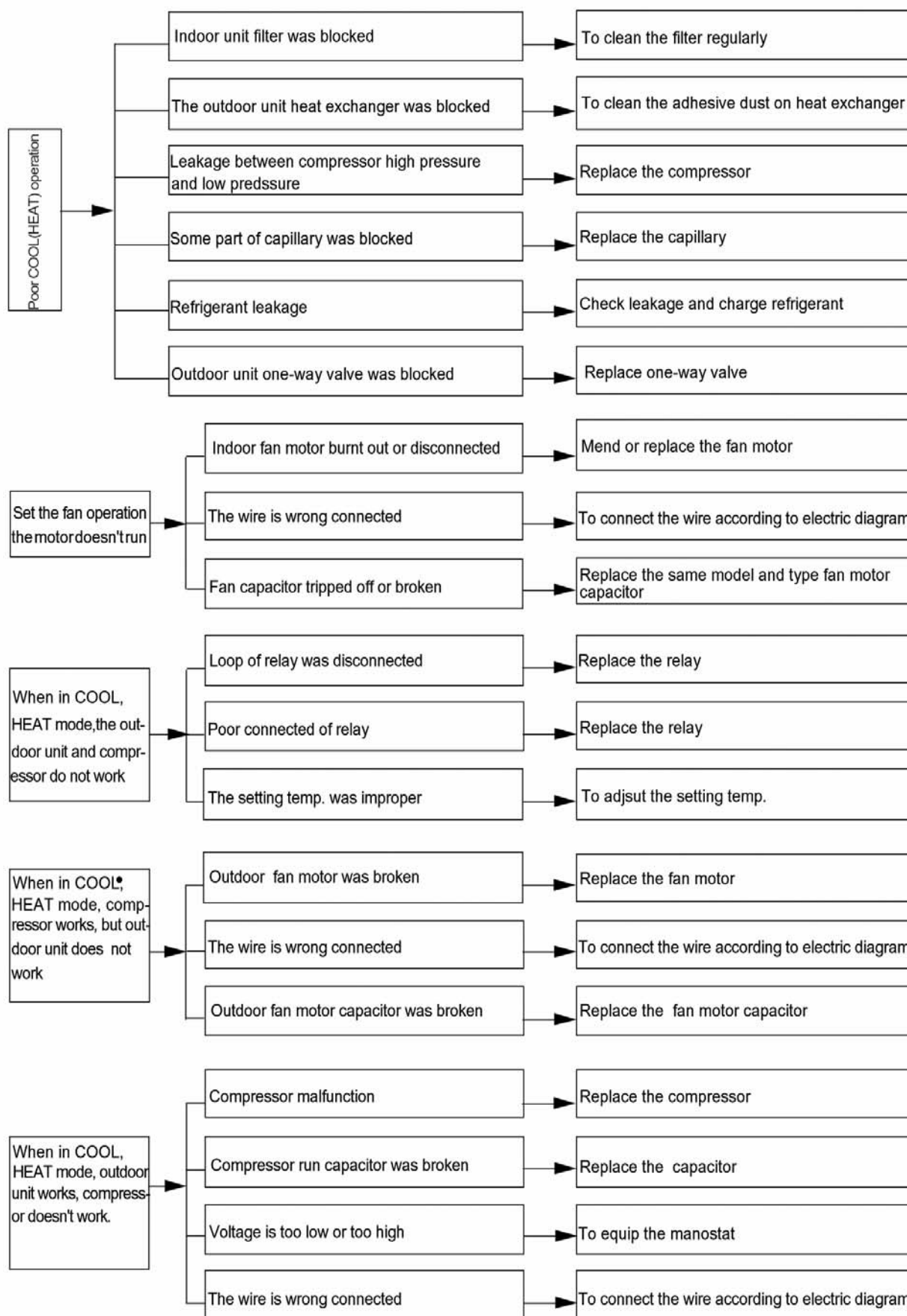

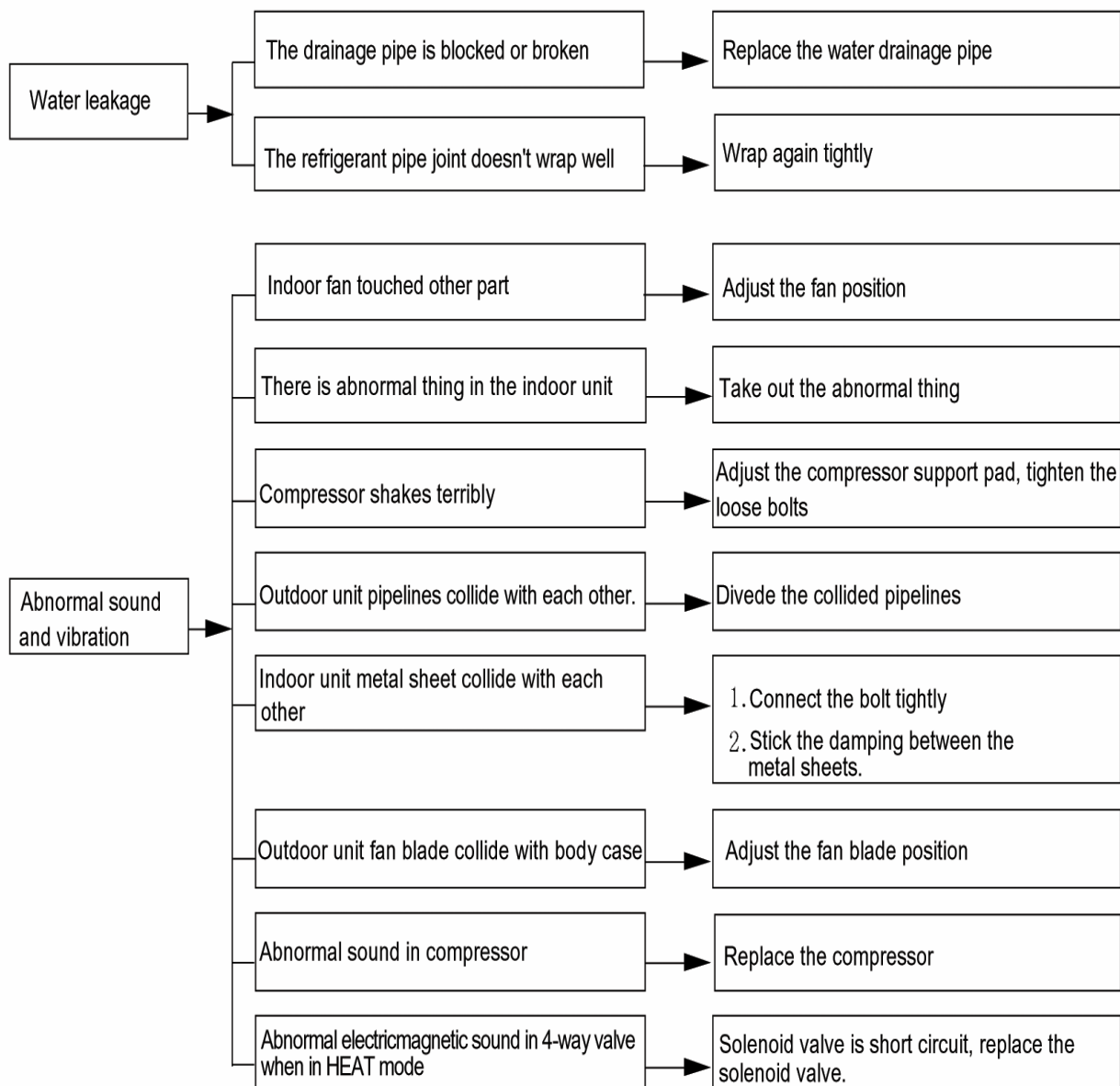





**Большая библиотека технической документации**  
<https://splitsystema48.ru/instrukcii-po-ekspluatacii-kondicionerov.html>  
**каталоги, инструкции, сервисные мануалы, схемы.**